

Models for Europe

230 Vac – 50 Hz.

Model Reference 152A

HI-END class A amplifier





Warning: device subjected to voltage 115Vac 50/60Hz. To avoid risk of electric shock do not open the lid, do not expose to moisture or rain, not groped repair on their own but refer only to trained



To avoid damage do not superimpose. make the goods always travel with their packaging, throw and avoid placing material on your device.

WARNING: BEFORE YOU START TO USE READ AS FOLLOWS INFORMATION

Safety information:

1. For best performance, please read this manual carefully. Keep it in a safe place for future reference. 2. Install the unit in a cool, dry, clean place away from windows, heat sources, intense vibration, dust, humidity, cold, and sources of humming (transformers, motors, etc.).. To prevent fire or shock hazard do not expose the unit to water and moisture. 3. Never open the equipment. If something should get into all 'inside, contact your dealer. 4. Do not operate the switches and other controls with force. When moving the unit, first disconnect the power cord and cables connected to other devices. Never pull the wires themselves.

5. The openings of the lid provides adequate ventilation of the unit. In case of obstruction of the same, the temperature inside the rooms very quickly. Then install the unit in a well-ventilated place, avoiding placing various objects in front of these openings to prevent fire and damage. Leave a space of at least 20 cm behind, 20 cm on both sides and 30 cm above the top panel of the machine to avoid fire or other damage. 6. The voltage used must be specified. Using this product with a current whose voltage is higher than specified is dangerous and may cause fire or other damage. EAM LAB is not responsible for any damage due to an incorrect use of the appliance.

DATASHEET

(RMS power both channel driven to 20 Hz at 20 KHz)

8 Ohm	150 W
4 Ohm	280 W
2 Ohm	250 W
4 Ohm	700 W

THD 0.007% (900Hz full power @ 20hm)**Input impedance** 22 Kohm balanced/ 22 Kohm single ended**THD Vs freq.** +/- 0,2% to 5Khz & 20Khz**S/N ratio** >105 db**DF** >400 (70Hz @ 8 Ohm)**Max V output** 5V**Max current drive** 42A**Measure** 550 x 250 x 600 mm**Weight** 70 Kg**Comsumption (@ 230Vac full power)** 6 A**Input connector** XLR neutrik and RCA /**Output connector** VBT binding post 8mm wire**Line filter** Schaffner 15 A**protection** TH – SVCS – ILP – IDCL**safety** 90° thermal switch

Preparation

Unpacking:

Carefully remove from the box your Amplifier and keep the original carton and packing materials for future trips, expeditions or long-term storage.

Introduction:

first of all thank you for choosing our a power amplifier. Amplifier built on modern and reliable high construction standards and with high-quality components of the latest generation. Every model of HA is tested according to strict functional testing to ensure high reliability in all conditions and provide high performance sound unchanging for long periods of time. The 5 year warranty on every component that constitutes the amplifier is further proof of its reliability. The high power available allows you to enjoy your music in full harmony without ever listening fatigue and dynamic compressions.

Precautions:

For the high power can be supplied to ensure that the speakers connected to it are able to withstand these powers worth the irreparable damage to speakers connected.

Before the installation:

remove your amplifier, taking care to keep it in the future if you ever require to be shipped to a service center EAMLAB to be overhauled or repaired.

Installation:

thanks to its ease of use, there are no particular notes of difficult interpretation. Before making any connections, make sure that the amplifier is turned OFF, preferably with the mains plug is disconnected to avoid unwanted random ignitions. Connect to the output terminals of the speaker cable of at least 2.5 sq mm cross section being particularly careful to observe the correct polarity to avoid unpleasant steps against acoustic ranging to compromising the overall noise. The section of the power cable that feeds the wall outlet where the amplifier must be connected to at least have a diameter of 2.5 mmq. For model HA600 and at least 1.6mmq. for HA300. This is to ensure the amplifier always the right energy reserve when it is subjected to high dynamic musical passages. It should be best to treat this aspect of the electrical installation if you intend to use the most of our amplifiers.

Panel Front controls:

fig.A.



1. ILP™ intelligent lock power

Indicates the operating status of 'amplifier

Indicates the operating status of the thermal and DC protections.

2. Switch ON/OFF

Function e protection

Ready to Power on

After making all connections correctly we are ready to turn on the amplifier.

You just made, the amplifier performs some set in the reset to ensure a safe operation, this is true both in power-on switch-off. As sometimes happens the major problems of high power amplifiers take over at power on or power down. Our amplifiers HA series are designed not to lie in this unfortunate situation.

Pressed the power switch on the front panel, the two LEDs

ILPTM (see fig. A) will flash for about 3 seconds and then stay on steady. These LEDs indicate the operating status of the protections that serve different functions listed below:

ILP™ (intelligent lock power):

At Power on:

- 1 - connect the speakers out after about 3 seconds (delay antibump). The LEDs become fixed after about 3sec.
- 2- resets the parameters of current and voltage of the output stages to ensure maximum efficiency
- 3- immediately disconnects the load in case of failure of the transistors
- 4 - disconnect the load in the event of a short circuit on the output stages
- 5 - disconnect the load in the event of a short circuit on the power cables
- 6 - disconnect the load in the event of prolonged clipping without damaging the speakers.

At the power off

- 1- immediately disconnects the outputs from the load

If the LEDs flash always:

In remote eventually that something can impair circuit **ILPTM** quickly intervene immediately disconnecting the load and blocking the amplifier. The LED or two LEDs (the 2 channels have 2 independent circuits ILP) will flash warning that something went wrong during the operation.

note: the circuit **ILPTM** also intervenes when the **DC** output offset should increase coming from the parameters set in the factory.

Proceed as follow:

turn the amp off and wait about 3 minutes to make sure that the circuit **ILPTM** resets every parameter. turn on the amplifier and observe the return to normal operation with LED ILP returning fixed. if the problem persists (LED always blinking) contact a service center EAMLAB.

Note:

it may happen sometimes, after the intervention of the circuit **ILPTM**, which is switched on again, the LED or LEDs come back fixed but the amplifier does not emit any sound.

This means that the circuit **ILPTM** is working again and the relay circuit that releases the load does not detect the DC component in the output because the circuit **ILPTM** the block in advance if it detects abnormalities in the output stages.
Even in this case, contact the service center.

Instruction:

In any case, do not ever groped to solve the problem alone, but immediatamnete contact theservicecenter. Any unauthorized intervention by EAMLAB immediately void the warranty.

THLTM thermal overload

The thermal protection system **THLTM** is activated only in the case in which the operating temperature of the final stages exceeds the threshold of 90 °.

The intervention **THL** will be signaled by the fixed LEDs on the front panel (see fig.) these LEDs will light when the heatsink temperature reaches 70 ° and the circuit tries to keep it stable working on current values and polarization of the power stages.

If the temperature still rise **THLTM** circuit turns off the relay to speaker at 90 °

If the system THL activates:

1. You can power off the amplifier and Letting it cool.

You can reset the amplifier on and leaving him

Notes:

All amplifier control and protection circuits are explained in the guide **ENGINEERING PRODUCT.**

Consult this guide to understand how it works

Connecting schematics

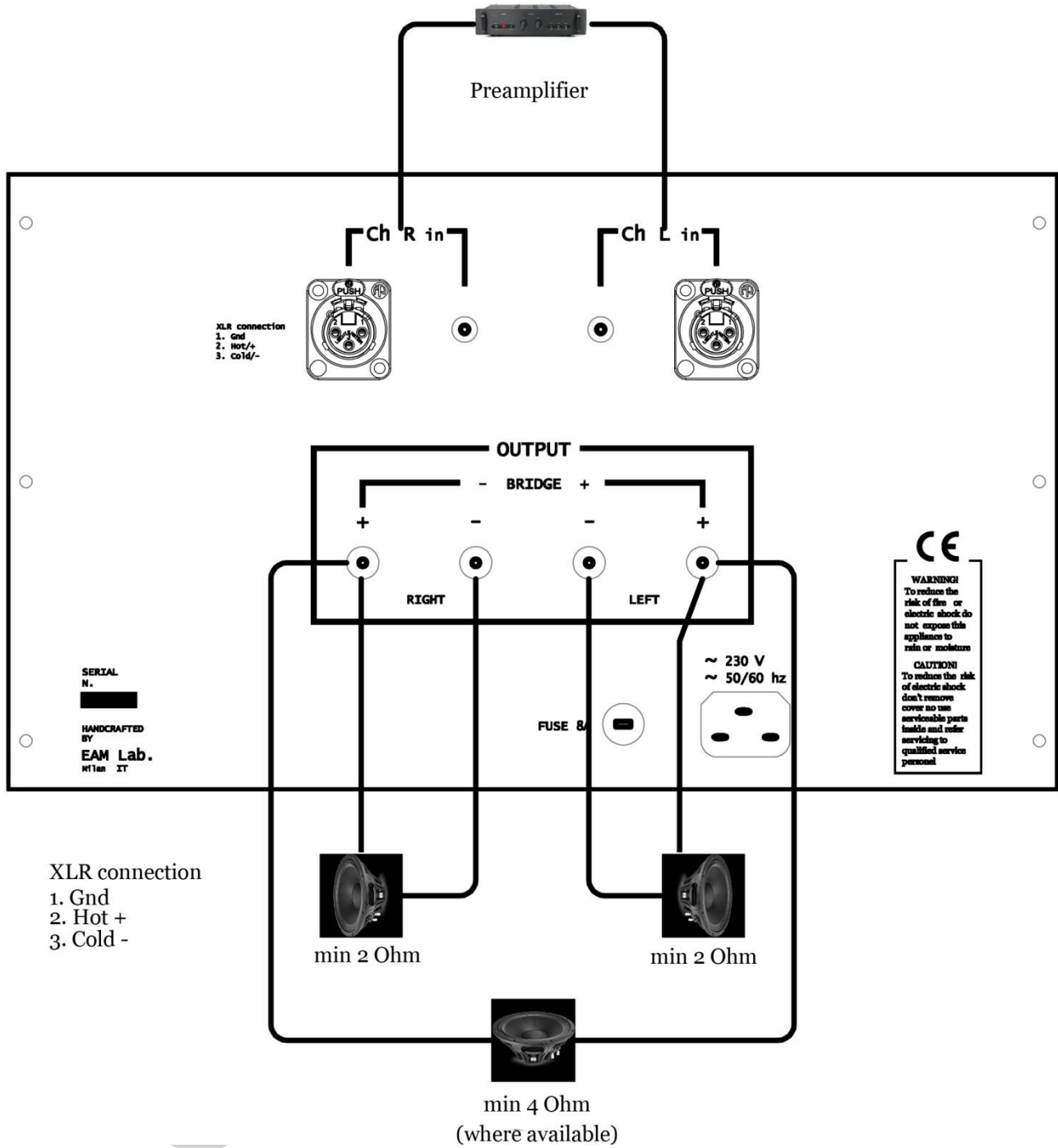

Reference 152A HI-END class A amplifier

Product engineering

PROJECT AND TYPE

The purity of sound reproduction of class A - HDCA.2 input stages with "instrumentation" components for an exceptional signal-to-noise ratio - innovative power circuit that uses super fast diodes to guarantee transient response times never achieved before - Sanken bipolar output device for unique performance. 2,000 VA toroidal transformer to provide maximum energy at the highest absolute levels of volume and impedance.

Reference152a is equipped with a separate double secondary transformer with a total of 2000 VA and a total filtering capacity of 233,000 Uf. with this equipment it provides 150 W rms per channel on 8 ohms in pure Class A 280 to 4 and 450 on 2 between 20 Hz and 20 KHz with a distortion of less than 0.03%. But not just power.

In Reference 152A we also wanted greater speed of response to transients, a neutral sound independent of sound pressure and reliability of operation in any condition. Particular care in the power supply circuit, such as the use of ultrafast diodes for rectifying to replace the classic rectifier bridges, the low-induction transformer with a yield of 97%, the aluminum film capacitors with very tight tolerances, have made us achieve the objectives set.

All the technology of this amplifier is enclosed in a beautiful anti-vibration steel chassis and a specially designed assembly to minimize any induced interference. Components of the latest generation and undisputed quality equip this powerful amplifier.

Innovative control and protection circuits always guarantee perfect and long-lasting operation in complete safety. THL, the circuit used to monitor the operating temperature, is entrusted to the LM35 probes and managed by the CPU. much more precise and reliable than normal thermal circuit breakers.

CONTROLS AND PROTECTION

The importance of better protecting electronics and connected loads is of primary importance to us at Eam Lab. For this reason we have developed effective protections that do not alter the musical signal in any way. Specifically for this model, they have also been integrated by a microprocessor which increases its effectiveness and precision of intervention.

IMPORTANTE:

Tutte le protezioni attive presenti nei circuiti di amplificazione sono progettate affinché non possano intervenire in nessun modo sul segnale audio che potrebbe invece degradare come avviene in molti casi su amplificatori non progettati a dovere.

IDCL™ (Impedance Detecting & Current Limiting)

IDCL is a protection circuit that constantly monitors the output current of the power output by comparing it with the load impedance. the circuit IDCL intervenes in the case in which the output current were to increase for several reasons. With this method you can use Reference 152A also with the next short-circuit impedance loads without the slightest hint to failure. The circuit IDCL is not a limiter but a real "protection" and its current intervention is not noticeable on the signal.

A side of the circuit is represented in its simplified part.

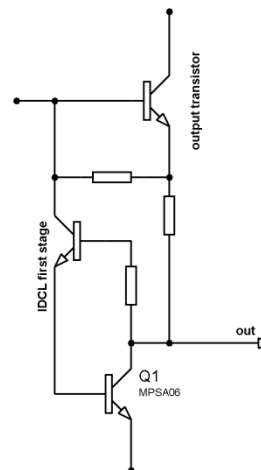

ILP™ (Intelligent Lock Power)

The protections ILP system including in a single circuit 3 different functions.

Detects any DC currents present on the end devices, blocking the exits and disconnecting the load connected. In this regard the task is entrusted to 2 Relay 30A with more than 500,000 cycles of contact. ILP is not a simple DC detector but a system of protections more complex able to warn each minimum variation of DC output voltage. even in case of prolonged clipping circuit intervenes. Working in tandem with IDCL these two devices are able to provide unmatched reliability for this amplifier.

SVCS™ (Servo Controlled Current State)

The power amplifier must be treated appropriately imposing and its management is entrusted to this circuit. The currents in the game, often very high, they are always kept under control even when the amplifier is turned on to begin work. To prolong the life of exceedingly transformer and capacitors the supply voltage is brought to regime only after a few seconds and not all at once. You go from a 30% to 100% in about 4 seconds after. In addition to this useful function I 'SVCS controls the power supplied from the transformer and limits the operation only in the event of excessive thermal dissipation gradually lowering the yield up to 70% of its capacity.

THL™ (Thermal Heat Limiting)

The temperature of the end devices is handled by this circuit which always guarantees the correct operation even in the event of excessive thermal stress. The circuit is activated when the temperature on the heat sink reaches the threshold of 70 ° c. and makes sure to keep it stable within a tolerance of 10% by acting on micro-variations of the polarization of the final stages. The two LEDs on the front panel indicate the operation of the circuit THL. This is a condition that occurs after a few hours of operation (in some cases after a few minutes, depending on the load connected) and the amplifier in this condition can work continuously without the slightest problem for many hours yet.

A thermal circuit breaker at 90 ° c. is however placed in series with the supply line to a further guarantee of safety intervention. In the unlikely event that the circuit THL does go faulty circuit breaker switches off the amplifier and turns it back on automatically when the temperature falls within the parameters of safe operation.